



Title	The Change of the Arc Temperatures of Electric Contacts with the number of times of the Make and Break
Author(s)	Itoyama, Kagehiro
Citation	長崎大学教育学部自然科学研究報告. vol.22, p.87-94; 1971
Issue Date	1971-02-28
URL	<a href="http://hdl.handle.net/10069/33059">http://hdl.handle.net/10069/33059</a>
Right	

This document is downloaded at: 2019-04-24T16:17:57Z

# The Change of the Arc Temperatures of Electric Contacts with the number of times of the Make and Break

by Kagehiro ITOYAMA

(Received October 30, 1970)

## Abstract

This experiment was applied to spectroscopic method for a short arc of Ag and Ag-CdO contacts at the breaking and was measured the change of the intensities of spectral lines with the number of times of the make and break. The number of times of the make and break did up to the 50000 times. The arc temperature was calculated by the ratio of one pair of AgI lines at the thermal equilibrium in the arc column. The temperature is between 3000°K and 5000°K under ordinary condition, however, it changes with the number of times of the make and break. The change of the arc temperatures have some periodical character and shows the peak value between 15000 and 25000 times for Ag contact, 20000 times for Ag-5%CdO contact, 25000 times for Ag-15%CdO contact. Considering Ag and Cd atoms in the arc column, the change of Ag atoms are in good agreement with the change of the arc temperature. Besides, at Ag-CdO contact, it also is confirmed with the spectroscopic that Cd atoms evaporate earlier than Ag atoms.

## 1. Introduction

Up to the present, the many studies have been taken on the arc of electric contacts, however, these seem to have not investigated in detail about the inside of arc owing to the complex phenomena and so on.

The Ag-CdO contact which is remarked and well received recently for the middle or heavy load, but has the only weak point in its character, this is a long arc duration, was studied by the present author.

Considering the Ag-CdO contact, the fundamental study of the combination contacts<sup>(1)</sup>, the statistical treatment of the arc duration, the study of the arc duration characteristics<sup>(2),(3)</sup> and the study of the arc temperature<sup>(4)</sup> have been done by the present author. By measuring the change of the intensities of the spectral lines with the number of times of the make and break at the contact spectroscopically, the temperature and the change of the number of Ag and Cd

atoms in the arc column for the short arc occurred at the contact, are investigated.

## 2. Experimental Procedure

The circuit used is shown in Fig. 1. As shown in Fig. 1, the two pairs of contacts named  $c_1$  and  $c_2$  respectively, are connected in a series. They are adjusted that an arc may arise at  $c_1$  contact when the  $c_1$  is switching off, and at  $c_2$  when the  $c_2$  is switched on, by the suitable holding of the output phase of the relay oscillator. In this case, the arc only at the breaking is studied. The current is supplied from the batteries and the load is the water resistance to keep off an inductance. The three kind of contacts are respectively made of Ag, Ag-5%CdO and Ag-15%CdO according to the sintering method.

A light of short arc is gathered on the slit of the spectroscope by using a convex lens and is splitted into some spectral lines by using a prism. The spectral lines are photographed by a camera on an *Okular linse* of the spectroscope. After these films were developed, a relative intensities of spectral lines were measured with the microphotometer. The film is NEOPAN SSS(ASA:200) and a developing time is seven minutes and a temperature of solution for developing is kept 20°C. A circuit condition is  $E=D.C.$  50V,  $I=5A$ . The measurements are taken every 5000 times from 5000 to 50000 times. The contact used has 5mm in diameter and 5mm in length, whose shape is a flat surface in the cathode and a spherical surface in the anode.

For a calculation of an arc temperature, a pair of spectra, the neutral atomic line of Ag are chosen, whose wavelength are 4210.94Å and 4476.08Å, with a consideration to the available range of the spectroscope (3900Å~7000Å) and the excitation energy of spectral lines. In addition, a spectrum line of 4799.92Å in CdI is used to find the behaviour of Ag and Cd atoms.

## 3. Principle of Measurement

According to the spectroscopy, equ. (1) shows the relation between  $I$ , intensity

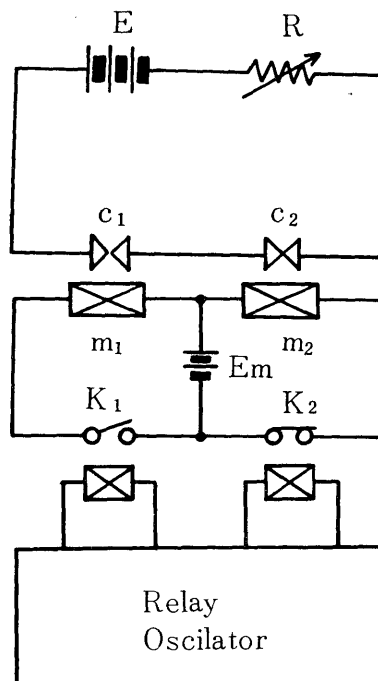

E: power supply.  
 R: water resistance.  
 $c_1, c_2$ : contact for the experiment.  
 $m_1, m_2$ : magnet.  
 $K_1, K_2$ : Switch.  
 $E_m$ : power supply for magnets.

Fig. 1 — Experimental circuit.

of spectrum line  $\nu$ , the frequency of that<sup>(5)</sup>

$$I = h\nu N_n A_{nm} \quad (1)$$

where  $h$  is Plank's constant,  $N_n$  is the number of atoms excited to state  $n$  in the arc column and  $A_{nm}$  is Einstein's probability coefficient of spontaneous emission. If the thermal equilibrium exists in this arc column, Boltzman's law is applied to  $N_n$  as follows,

$$N_n = N_0 \frac{g_n}{u(T)} \exp\left(-\frac{E_n}{kT}\right) \quad (2)$$

where  $N_0$  is the particle density of the ground state,  $u(T)$  is the partition function for any particular atom or ion,  $g_n$  is the statistical weight of the upper level,  $E_n$  is the energy of the upper level,  $k$  is Boltzman's constant and  $T$  is the absolute temperature.

Substituting equ. (2) into equ. (1), we have

$$I = N_0 \frac{g_n}{u(T)} A_{nm} h \nu \exp\left(-\frac{E_n}{kT}\right) \quad (3)$$

A intensity ratio of spectrum line at the same wavelength is shown as equ. (4) from equ. (1) and equ. (3).

$$\frac{I_1}{I_2} = \frac{N_{n1}}{N_{n2}} \frac{u(T_1)}{u(T_2)} \exp\left(\frac{1}{kT}(E_{n2} - E_{n1})\right) \quad (4)$$

The ratio of spectrum line at the different element, for example at Ag and Cd, is shown as equ.(5) from equ.(3)

$$\begin{aligned} \frac{I_{Cd}}{I_{Ag}} &= \frac{A_{nmCd}}{A_{nmAg}} \frac{\nu_{Cd}}{\nu_{Ag}} \frac{N_{nCd}}{N_{nAg}} \\ &= \frac{N_{0Cd}}{N_{0Ag}} \frac{u(T)_{Ag}}{u(T)_{Cd}} \frac{\nu_{Cd}(g_n A_{nm})_{Cd}}{\nu_{Ag}(g_n A_{nm})_{Ag}} \exp\left(\frac{1}{kT}(E_{nAg} - E_{nCd})\right) \end{aligned} \quad (5)$$

Equ. (5) shows a ratio of excited atoms of Cd and Ag in the arc, where the subscript Ag designate quantities associated with Ag neutral atom and its spectrum and Cd designate Cd neutral atom and its spectrum.

The arc temperature was given by the ratio of the intensity of spectrum line at the different wavelength of the same element. Substituting  $\nu = c/\lambda$  into equ. (3), where  $c$  is the light velocity and  $\lambda$  the wavelength of line. Introducing a value for  $k$ , equ. (3) becomes

$$T = \frac{5040(E_{n1} - E_{n2})}{\log \frac{g_{u1} A_{nm1}}{g_{n2} A_{nm2}} - \log \frac{\lambda_1}{\lambda_2} - \log \frac{I_{\lambda 1}}{I_{\lambda 2}}} \quad (6)$$

where the dimension of  $E_{n1}$ ,  $E_{n2}$  is electron-volt. Substituting known  $gA$ -value<sup>(6)</sup> into equ. (6), the arc temperature of contact is calculated.

In the case of short arc, it cannot be known whether the thermal equilibrium exists in its arc column or doesn't. But it seems to be quite natural to suppose that there exists the thermal equilibrium in the contact arc whose duration is millisecond order, because equ. (6) has been able to be used for the spark whose duration is microsecond order, and this means the existence of the thermal equilibrium.

#### 4. Results and Discussion

The results of some microphotometric analysis of the short arc of Ag-15%CdO contact are shown in Fig. 2. The change of the ratio of spectral line intensities ( $I_{4210}/I_{4476}$ ) of one pair of AgI lines are shown in Fig. 3. These ratios have some periodical character. Fig. 3. shows the peak value between 15000 and 25000 times for Ag contact, between 20000 times for Ag-5%CdO contact, between 25000 times for Ag-15%CdO contact. Fig. 4. shows the change of arc temperature with the number of times of the make and break. These temperatures are 3000°K to 5000°K under ordinary condition and are in nearly agreement with the values of arc temperature in other literature<sup>(7)</sup>. Further, the dash line in Fig. 4. is the value which cannot be given by equ. (6). The periodicity of arc temperature in contact is due to the following reasons;

- (1) the increase of Cd atoms in the arc column.
- (2) the increase of Ag atoms in the arc column.

Considering the reason (1), the experimental results which were obtained to use equ. (5) are shown in Fig. 5. The ratio of the intensities of spectral lines, whose wavelength are 4799.92Å at Cd atom and 4210.94Å at Ag atom represent the ratio of excited Cd atoms to excited Ag atoms. Fig. 5. cannot be found an apparent comparison between the change of arc temperature, however, we will be found that the arc temperature increases as the excited atoms of Ag increase in the arc column. The number of excited Cd atoms are more than that of excited Ag atoms. This means

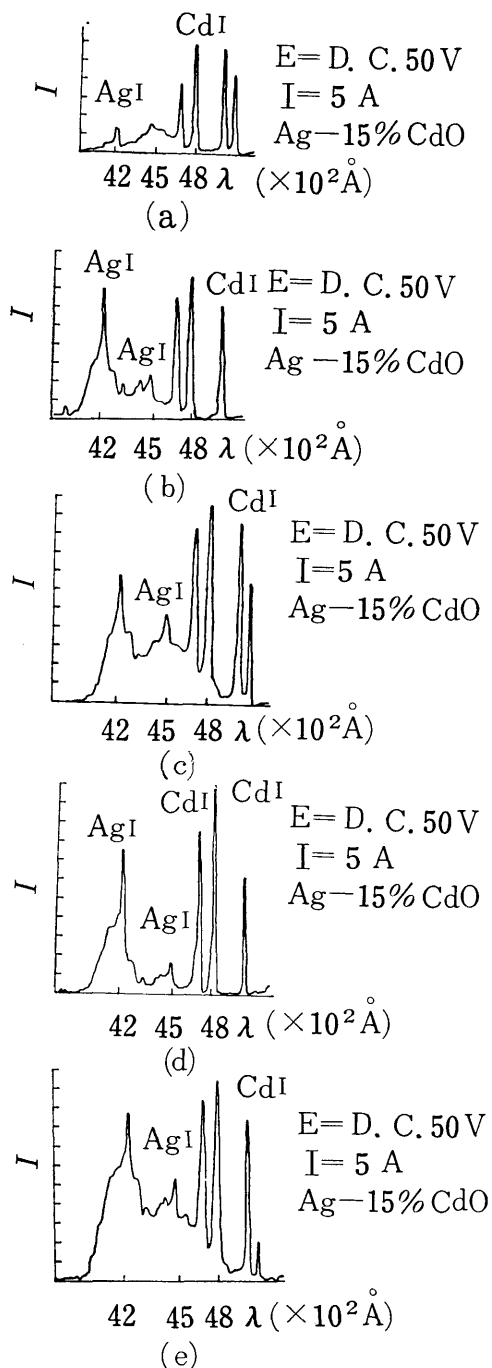

Fig. 2 — The change of the relative intensities of spectral lines with the number of times of the make and break. (a) the ten thousandth times, (b) the twenty thousandth times, (c) the thirty thousandth times, (d) the forty thousandth times, (e) the fifty thousandth times.

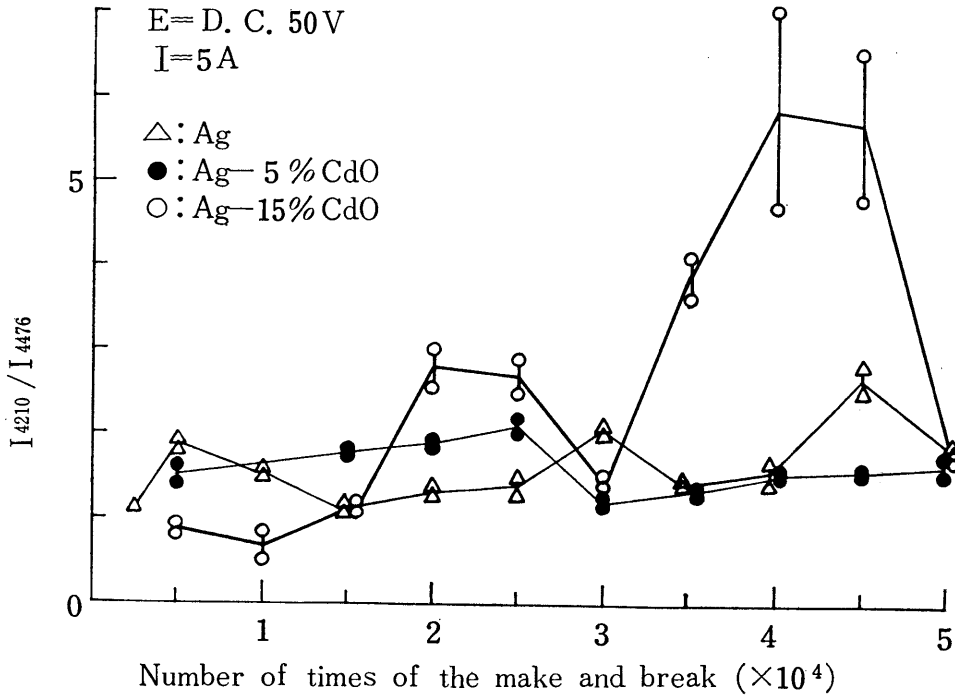

Fig. — 3 The change of the ratio of spectral-line intensities ( $I_{4210}/I_{4476}$ ) with the number of times of the make and break.

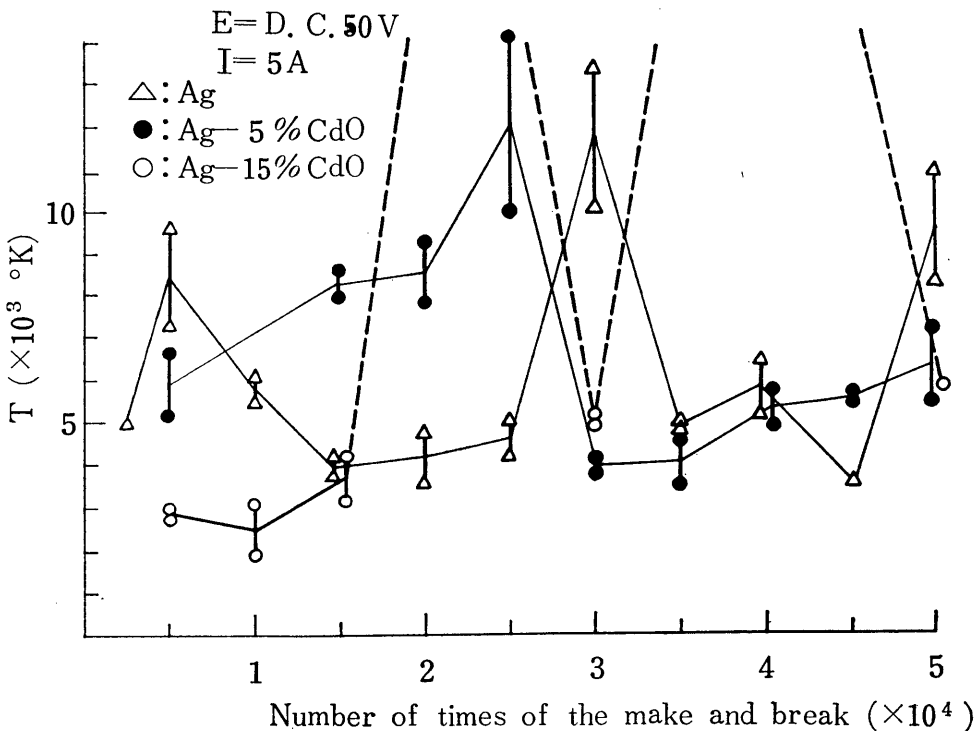

Fig. 4 — The change of the arc temperature of electric contact with the number of times of the make and break.

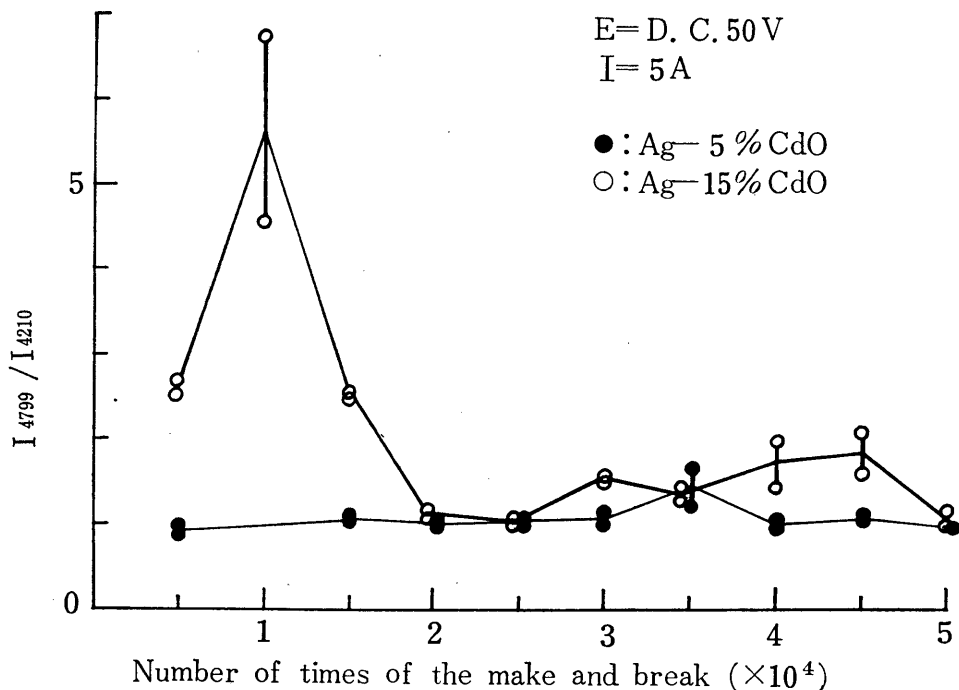

Fig. 5 — The change of the ratio of spectral-line intensities ( $I_{4799}/I_{4210}$ ) with the number of times of the make and break.

that boiling point of Cd is lower than Ag and evaporated earlier than Ag is. This is in agreement with the experimental results which are shown in Fig. 6, that shows the change of the contact surface with the number of times of the make and break and also represents which is described above.

Considering the reason (2), the experimental results which were obtained to use equ. (4) are shown in Fig. 7. They represent the change of excited atoms of Ag for the five-thousandth times. The wavelength is  $4210.94\text{\AA}$  in AgI lines. As shown in Fig. 7, the increase and decrease in neutral excited atoms of Ag is in good agreement with the tendency of arc temperature. This means that Ag atoms play the most important part in arc temperature at Ag and Ag-CdO contact.

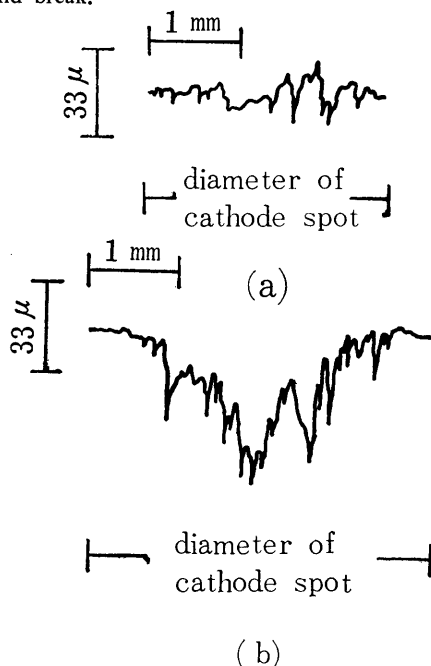

Fig. 6 — The change of the cathode surface of Ag-15% CdO contact with the number of times of the make and break. (a) the five hundredth times, (b) the five thousandth times.

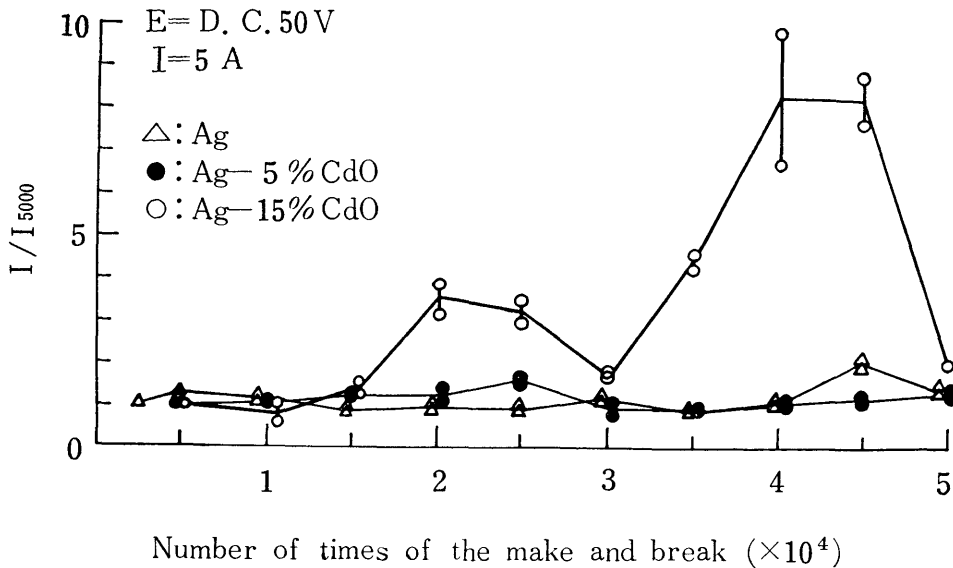

Fig. -- 7 The change of the ratio of spectral-line intensities ( $I/I_{5000}$ ) with the number of times of the make and break. (based on the five thousandth times.)

## 5. Conclusion

Summarizing the results above, we obtained as follows. (1) The temperature of short arc of Ag and Ag-CdO contact is between  $3000^{\circ}K$  and  $5000^{\circ}K$  in ordinary condition. (2) The temperature of short arc of the contact shows a peak value at periodically. Its period is 15000 to 25000 times for Ag contact, 20000 times for Ag-5%CdO contact, 25000 times for Ag-15%CdO contact. (3) The increase and decrease of Ag atoms in the arc column has a great influence upon the periodicity of the peak value of arc temperature. (4) The effect of the variation of Cd atoms is not remarkable for the arc temperature, but the increase of Cd atoms shows a tendency to drop the arc temperature in ordinary. (5) At Ag-15%CdO contact, Cd atoms increase in the arc column in the early times of the make and break. This result is in agreement with the measurement of contact surface.

The attempt which was applied to spectroscopic method for the short arc of contact is a small in number, there are a few reports. Especially, such a report which operate a contact for long time cannot be found up to the present. The results in this paper will serve the production and choice of contact to good purpose.

The author would like to express his sincere thanks to Prof. T. Aida at the Kumamoto University for his constant guidance and encouragement throughout this work.



### References

- (1) K. Itōyama : A Consideration for the Arc Duration of Ag and Ag-CdO Combination Contact, Research Rep. Sasebo Tech. College, No. 9 (1970).
- (2) K. Itoyama, T. Aida: Arc Duration Characteristics and Empirical Formula of Ag-CdO Contact, IECE of Japan mechanical parts meeting data **EMC 68-23** (1968-12).
- (3) K. Itoyama : The Effect of Metal Vapour on the Arc Duration Characteristics of Electric Contacts, Research Rep. Sasebo Tech. College, No. 6 (1970).
- (4) K. Itoyama, T. Osima, H. Inoue : On a Study of the Short Arc of Contact with the Spectral-line Intensities (No. 2), national conference of IECE, No. 336 (1970).
- (5) C. H. Corliss : Ionization in the Plasma of a Copper Arc, J. Research NBS **66A** (Phys.& Chem.), 169 (1962b).
- (6) NBS : Tables of Experimental Transition Probabilities for Lines of 112 Spectra, NBS Monograph, 53 (1962).
- (7) C. H. Corliss : Temperature of a Copper Arc, J. Research NBS **66A** (Phys & Chem.), 5 (1962a).