



|            |  |
|------------|--|
| Title      | Laminar heat transfer in the thermal entrance region of concentric annuli with moving heated cores : Part II : The cases with the third and fourth kinds of thermal boundary condition |
| Author(s)  | Davaa, Ganbat; Shigechi, Toru; Momoki, Satoru  |
| Citation   | 長崎大学工学部研究報告 Vol.32(59) p.51-58, 2002   |
| Issue Date | 2002-07  |
| URL        | <a href="http://hdl.handle.net/10069/5210">http://hdl.handle.net/10069/5210</a>  |
| Right      |  |

This document is downloaded at: 2020-10-28T18:07:12Z

# Laminar heat transfer in the thermal entrance region of concentric annuli with moving heated cores

## (Part II: The cases with the third and fourth kinds of thermal boundary condition)

by

Ganbat DAVAA\*, Toru SHIGECHI\*\* and Satoru MOMOKI\*\*

Consideration is given to the effects of viscous dissipation on the developing heat transfer between a fully developed laminar non-Newtonian fluid flow and a concentric annular geometry with a moving heated core. In this report, the results with the third and fourth kinds of thermal boundary condition are presented. Applying the shear stress described by the modified power-law model, the energy equation including the viscous dissipation term is solved numerically. The effects of radius ratio, flow index, relative core velocity, dimensionless shear rate parameter and Brinkman number on temperature distribution and Nusselt numbers are discussed.

### 1. Introduction

In the previous report<sup>(1)</sup>, numerical solutions the heat transfer of a non-Newtonian fluid in a concentric annulus with an axially moving core were obtained for thermal entrance region with first and second boundary conditions.

In this paper, the entrance-region heat transfer between a fully developed laminar fluid flow and a concentric annular geometry with a moving heated core is studied numerically. Applying the fully developed velocity profile reported for the modified power-law model in the previous report<sup>(2)</sup>, the energy equation including the viscous dissipation term is solved numerically using the finite difference method for the thermal boundary conditions of third kind and fourth kind. The effects of the radius ratio, relative velocity of the core, the flow index and dimensionless shear rate parameter and Brinkman number on the temperature distribution and Nusselt numbers are discussed.

### Nomenclature

|       |  |
|-------|--|
| $Br$  | Brinkman number                          |
| $c_p$ | specific heat at constant pressure       |
| $D_h$ | hydraulic diameter $\equiv 2(R_o - R_i)$ |
| $k$   | thermal conductivity                     |
| $m$   | consistency index                        |
| $n$   | flow index                               |
| $Pe$  | Peclet number                            |
| $r$   | radial coordinate                        |

|       |   |
|-------|---|
| $r^*$ | dimensionless radial coordinate $\equiv r/D_h$                    |
| $R$   | radius  |
| $q$   | wall heat flux  |
| $T$   | temperature   |
| $u_m$ | average velocity of the fluid                                     |
| $u^*$ | dimensionless velocity $\equiv u/u_m$                             |
| $U^*$ | dimensionless relative velocity of the moving core $\equiv U/u_m$ |
| $z$   | axial coordinate  |
| $z^*$ | dimensionless axial coordinate<br>$= z/(PeD_h)$                   |

### Greek Symbols

|            |   |
|------------|---|
| $\alpha$   | radius ratio $\equiv R_i/R_o$   |
| $\beta$    | dimensionless shear rate parameter  |
| $\eta_a$   | apparent viscosity  |
| $\eta_a^*$ | dimensionless apparent viscosity $\equiv \eta_a/\eta^*$                                       |
| $\eta^*$   | reference viscosity   |
| $\rho$     | density   |
| $\xi$      | transformed dimensionless radial coordinate $\equiv [2(1 - \alpha)r^* - \alpha]/(1 - \alpha)$ |

### Subscripts

|    |   |
|----|---|
| b  | bulk                                    |
| e  | inlet                                   |
| i  | inner tube                              |
| ii | at the inner wall with the inner heated |
| o  | outer tube                              |
| oi | at the outer wall with the inner heated |

### 2. Analysis

The physical model for the analysis is shown in Fig.1. The inner core tube is moves axially at a constant velocity,  $U$ . The assumptions used in the analysis are:

1. The flow is incompressible, steady-laminar, and fully developed hydrodynamically.
2. The fluid is non-Newtonian and the shear stress may be described by the modified power-law model<sup>(3)</sup>, and the physical properties are constant except viscosity.
3. The body forces and axial heat conduction are neglected.

### Heat transfer

The energy equation together with the assumptions above is written as

$$k \frac{1}{r} \frac{\partial}{\partial r} \left( r \frac{\partial T}{\partial r} \right) + \tau \left( \frac{du}{dr} \right) = \rho c_p u \frac{\partial T_b}{\partial z}. \quad (1)$$

The velocity,  $u$ , and its gradient,  $\frac{du}{dy}$ , the shear stress,  $\tau$ , have been evaluated and reported in the previous report<sup>(2)</sup>.

The thermal boundary conditions:

(1) The third kind (constant wall temperature at the moving core with the outer tube insulated):

$$\begin{cases} T^{(3)} = T_i^{(3)} & \text{at } r = R_i \\ \frac{\partial T^{(3)}}{\partial r} = 0 & \text{at } r = R_o \end{cases} \quad (2)$$

(2) The fourth kind (constant heat flux at the moving core and the temperature of the outer tube is kept equal to the uniform entering fluid temperature):

$$\begin{cases} -k \frac{\partial T^{(4)}}{\partial r} = q_i & \text{at } r = R_i \\ T^{(4)} = T_e & \text{at } r = R_o \end{cases} \quad (3)$$

The initial condition is:

$$z = 0 : \quad T^{(k)} = T_e \\ \text{for } R_i \leq r \leq R_o \quad (k = 3 \text{ or } 4) \quad (4)$$

The Nusselt numbers are defined as:

$$Nu_{ii}^{(k)} = \frac{h_{ii}^{(k)} \cdot D_h}{k} \quad \text{for } k = 3 \text{ or } 4 \quad (5)$$

$$Nu_{oi}^{(4)} = \frac{h_{oi}^{(4)} \cdot D_h}{k} \quad (6)$$

where the heat transfer coefficients are defined as:

$$h_{ii}^{(3)} \equiv \frac{-k \frac{\partial T^{(3)}}{\partial r} \Big|_{R_i}}{T_i^{(3)} - T_b^{(3)}} \quad (7)$$

$$h_{ii}^{(4)} \equiv \frac{q_i}{T_i^{(4)} - T_b^{(4)}} \quad (8)$$

$$h_{io}^{(4)} \equiv \frac{k \frac{\partial T^{(4)}}{\partial r} \Big|_{R_o}}{T_o^{(4)} - T_b^{(4)}} \quad (9)$$

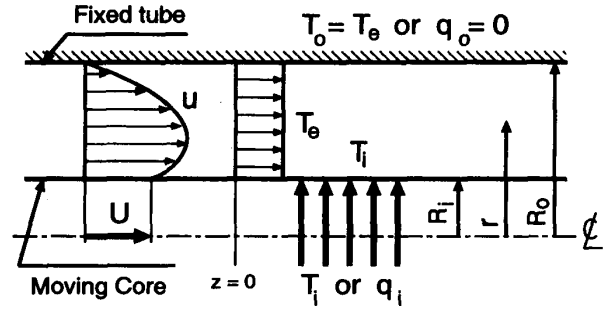

Fig.1 Schematic of a concentric annulus with an axially moving core

Thus, the various Nusselt numbers are calculated as:

$$Nu_{ii}^{(3)} = \frac{D_h}{T_i^{(3)} - T_b^{(3)}} \left[ -\frac{\partial T^{(3)}}{\partial r} \Big|_{R_i} \right] \quad (10)$$

$$Nu_{ii}^{(4)} = \frac{D_h}{T_i^{(4)} - T_b^{(4)}} \left[ \frac{q_i}{k} \right] \quad (11)$$

$$Nu_{io}^{(4)} = \frac{D_h}{T_o^{(4)} - T_b^{(4)}} \left[ -\frac{\partial T^{(4)}}{\partial r} \Big|_{R_o} \right] \quad (12)$$

Introducing a dimensionless temperature,  $\theta$ , defined as

$$\theta^{(3)} \equiv \frac{T^{(3)} - T_e}{T_i^{(3)} - T_e} \quad (13)$$

$$\theta^{(4)} \equiv \frac{k [T^{(4)} - T_e]}{q_i D_h} \quad (14)$$

the energy equation and the boundary conditions may be expressed in the dimensionless forms as

$$\frac{1}{r^*} \frac{\partial}{\partial r^*} \left( r^* \frac{\partial \theta}{\partial r^*} \right) + Br \cdot \eta_a^* \left( \frac{du^*}{dr^*} \right)^2 = u^* \frac{\partial \theta}{\partial z^*} \quad (15)$$

(1) The boundary condition of the third kind:

$$\begin{cases} \theta^{(3)} = 1 & \text{at } r^* = \frac{\alpha}{2(1-\alpha)} \\ \frac{\partial \theta^{(3)}}{\partial r^*} = 0 & \text{at } r^* = \frac{1}{2(1-\alpha)} \end{cases} \quad (16)$$

(2) The boundary condition of the fourth kind:

$$\begin{cases} \frac{d\theta^{(4)}}{dr^*} = -1 & \text{at } r^* = \frac{\alpha}{2(1-\alpha)} \\ \theta^{(4)} = 0 & \text{at } r^* = \frac{1}{2(1-\alpha)} \end{cases} \quad (17)$$

The initial condition is:

$$z^* = 0 : \quad \theta^{(k)} = 0 \\ \text{for } \frac{\alpha}{2(1-\alpha)} \leq r^* \leq \frac{1}{2(1-\alpha)} \quad (k = 3 \text{ or } 4) \quad (18)$$

where

$$Br^{(3)} \equiv \frac{\eta^* u_m^2}{k [T_i^{(3)} - T_e]} \quad (19)$$

$$Br^{(4)} \equiv \frac{\eta^* u_m^2}{D_h q_i} \quad (20)$$

The dimensionless apparent viscosity,  $\eta_a^*$ , and reference viscosity,  $\eta^*$ , have been reported in the previous report<sup>(2)</sup>.

Nusselt numbers at the tube walls:

$$Nu_{ii}^{(3)} = - \frac{1}{1 - \theta_b^{(3)}} \frac{\partial \theta^{(3)}}{\partial r^*} \Big|_{\frac{\alpha}{2(1-\alpha)}} \quad (21)$$

$$Nu_{ii}^{(4)} = \frac{1}{\theta_i^{(4)} - \theta_b^{(4)}} \quad (22)$$

$$Nu_{oi}^{(4)} = \frac{1}{\theta_o^{(4)} - \theta_b^{(4)}} \frac{\partial \theta^{(4)}}{\partial r^*} \Big|_{\frac{1}{2(1-\alpha)}} \quad (23)$$

where the dimensionless bulk temperature,  $\theta_b$ , is defined as

$$\theta_b^{(k)} = \frac{8(1-\alpha)}{1+\alpha} \int_{\frac{\alpha}{2(1-\alpha)}}^{\frac{1}{2(1-\alpha)}} u^* \theta^{(k)} r^* dr^* \quad (24)$$

### 3. Results and discussion

The calculation has been carried out by using the finite difference method. The range of parameters considered are:

- The radius ratio:  $0.2 \leq \alpha \leq 1.0$
- The relative velocity:  $0 \leq U^* \leq 1.0$
- The flow index:  $0.5 \leq n \leq 1.5$
- Dimensionless shear rate parameter:  
 $10^{-5} \leq \beta \leq 10^5$

Brinkman number: 0.0, 0.01, 0.05 and 0.1.

The mesh sizes used in the numerical calculation are shown below.

a. Axial direction ( $\Delta z^*$ ):

$$\begin{aligned} 0 < z^* \leq 10^{-3} &: \quad \Delta z^* = 10^{-9} \\ 10^{-3} < z^* \leq 1 &: \quad \Delta z^* = 10^{-3} \end{aligned}$$

b. Radial direction ( $\Delta \xi$ )

$$\Delta \xi = 1/100.$$

The development of the non-dimensional temperature profiles in the thermal entrance region of a concentric annulus with a heated core for the two kinds of the boundary conditions ( $k = 3$  and  $4$ ) are presented in Fig.2a and Fig.2b, respectively, for the same condition ( $\alpha = 0.5$ ,  $n = 0.5$ , power law fluid ( $\beta = 10^5$ ) and  $U^* = 1.0$ ). The figures illustrate clearly how the temperature profiles develop for the two different boundary conditions.

The effects of the relative velocity,  $U^*$ , on the development of temperature profiles are demonstrated in Figs.2a and 2c for the third kind of boundary condition ( $k = 3$ ). It is seen that the fluid temperature increase is less rapid for larger values of the core velocity.

The effects of viscous dissipation on the development of temperature profiles for  $\alpha = 0.5$ ,  $n = 0.5$ ,  $\beta = 10^5$  and  $U^* = 1.0$  for the third kind of boundary condition ( $k = 3$ ) are shown in Fig.2a and 2d.

The effect of the moving core velocity on Nusselt number at the tube walls are shown in Figs.3a to 3c at given values of  $Br = 0.0$  and  $\alpha = 0.5$  for three different fluids ( $n < 1.0$  pseudoplastic,  $n = 1.0$  Newtonian and  $n > 1.0$  dilatant).

The calculation results of the particular case of Newtonian fluids ( $n = 1.0$ ) with neglected viscous dissipation ( $Br = 0.0$ ) are compared with the predictions by Shah and London<sup>(4)</sup> for the stationary core ( $U^* = 0$ ) and by Shigechi and Araki<sup>(5)</sup> for the moving core ( $U^* = 1.0$ ), respectively. Even at small values of  $z^*$ , it can be seen in Figs.3a, 3b and 3c that the agreement is excellent. The effect of the relative velocity of the moving core tube is always to increase the values of Nusselt numbers,  $Nu_{ii}$  and to decrease the values of Nusselt numbers,  $Nu_{oi}$ , for the given conditions of  $\alpha$  and  $Br$ .

The viscous dissipation effects on Nusselt number are shown in Figs.4 to 6 for two different fluids. With an increase in Brinkman number  $Nu_{ii}$  decreases for  $U^* = 0.0$  and  $Nu_{oi}$  increases for  $U^* = 0.0$  and  $U^* = 1.0$ .

For the third kind of boundary condition  $Br$  effects strongly on  $Nu_{ii}$  in both the thermally developing and developed regions when the core is fixed.  $Nu_{ii}$  decreases with an increase in  $Br$ . For the moving core in the thermal entrance region the effect of the  $Br$  on  $Nu_{ii}$  is almost negligible but in the fully developed region  $Nu_{ii}$  increases with an increase in  $Br$ .

For the fourth kind of boundary condition,  $Br$  has a strong effect on  $Nu_{ii}$  at the thermally fully developed region while the core is fixed. But for the case of the moving core the effect of the Brinkman number is very small at both the thermal entrance region and the fully developed region.

### 4. Conclusions

The heat transfer between a fully developed laminar fluid flow and concentric annular geom-

etry with a moving heated core of fluid or solid body is studied with the two different boundary conditions.

For equal conditions, increasing  $U^*$ , an increase in Nusselt numbers  $Nu_{ij}$  as  $Nu_{oi}$  decreases for all the cases of 1st, 2nd, 3rd and 4th kind.  $Br$  affects strongly on Nusselt number at the unheated fixed tube.

Reference

1. G.Davaa, T.Shigechi and S.Momoki "Laminar heat transfer in the thermal entrance region of concentric annuli with moving heated cores (Part I: the cases with the first and second kinds of thermal boundary conditions)" *Reports of the Faculty of Engineering, Nagasaki University*, vol.32, No.59, (2002).
2. G.Davaa, T.Shigechi and S.Momoki "Fluid flow for modified power law fluids in concentric annuli with axially moving cores" *Reports of the Faculty of Engineering, Nagasaki University*, vol.32, No.58, p.83-90, (2002).
3. M.Capobianchi and T.F.Irvine, "Predictions of pressure drop and heat transfer in concentric annular ducts with modified power law fluids" *Wärme-und Stoffübertragung*, 27, p.209-215, (1992).
4. Shah,R.K. and London,A.L., "Laminar flow forced convection in ducts", *Advances in Heat Transfer*, Supplement 1, Academic Press, (1970).
5. K.Araki, "Laminar heat transfer in annuli", *Department of Mechanical Engineering, Nagasaki University*, Master thesis, (1991) (in Japanese).

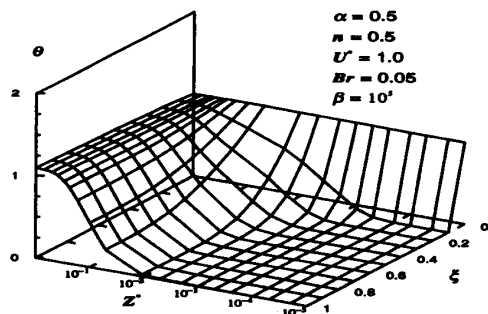

Fig.2.a Development of temperature profiles (3rd kind)

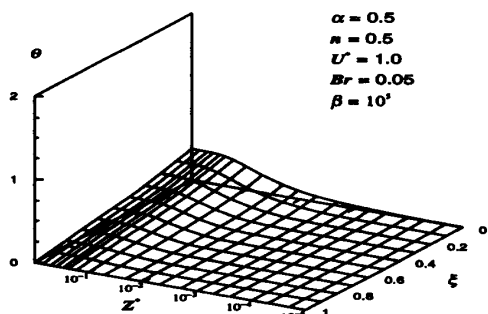

Fig.2.b Development of temperature profiles (4th kind)

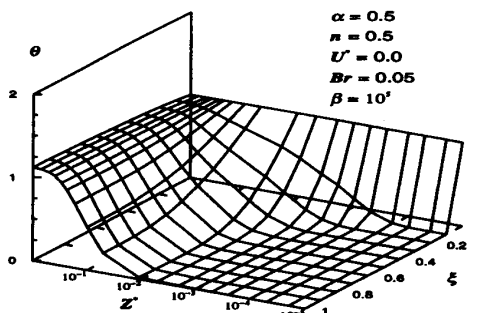

Fig.2.c Relative velocity,  $U^*$  on the development of temperature profiles (3rd kind)

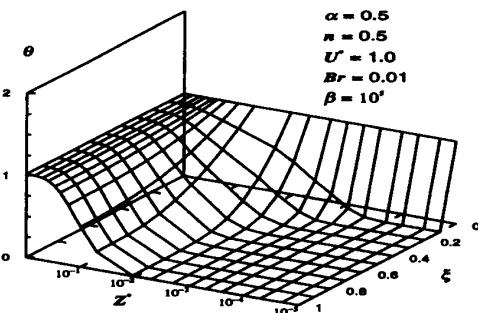
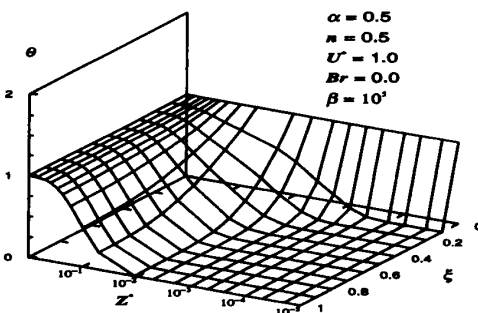
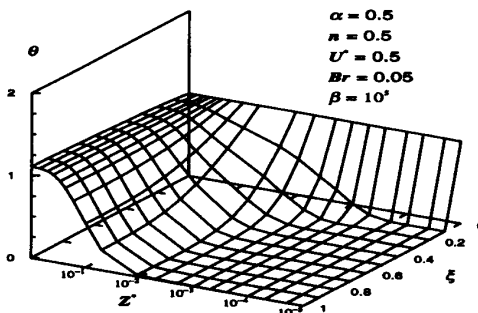

Fig.2.d Effect of  $Br$  on the development of temperature profiles (3rd kind)

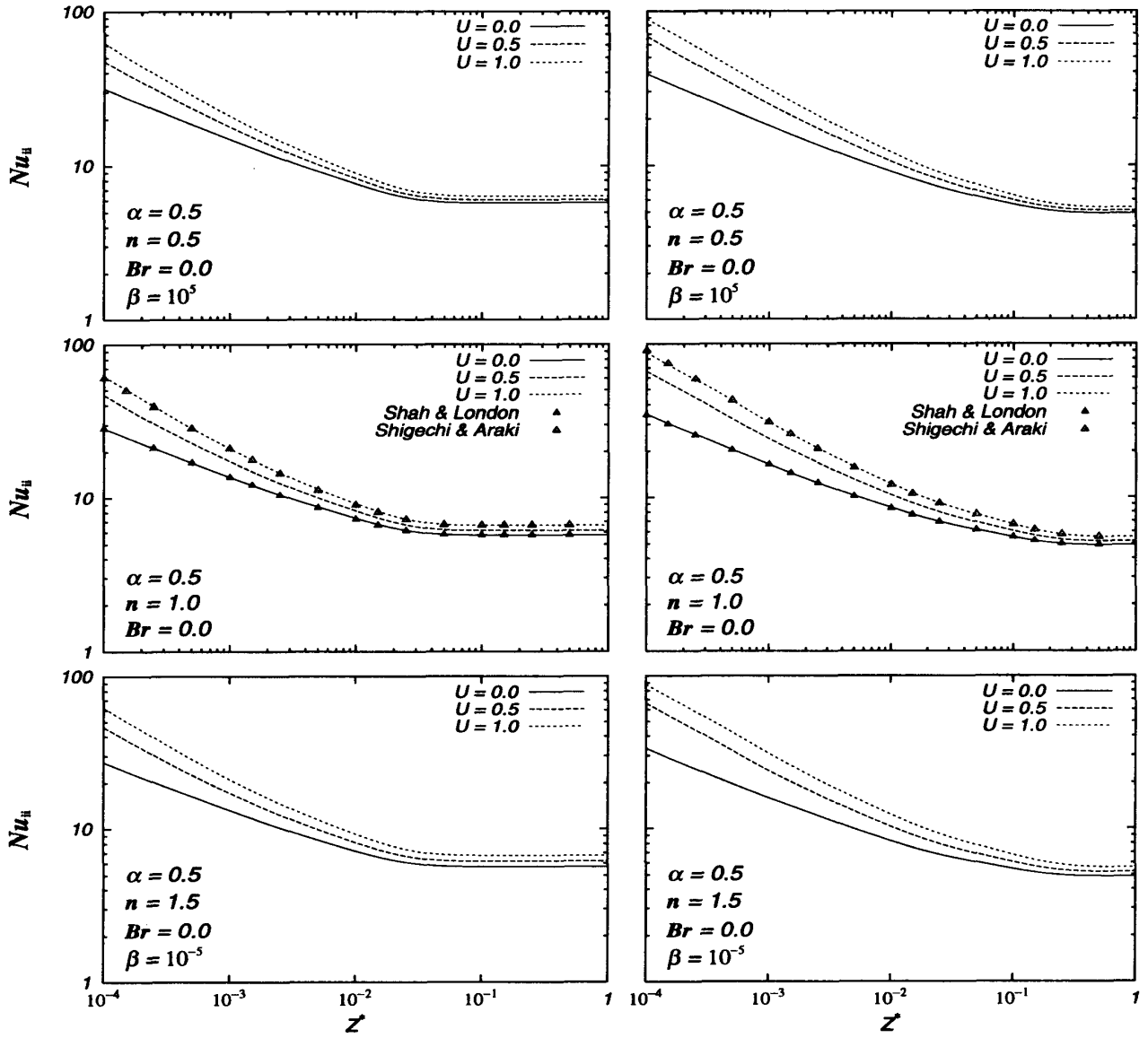

Fig.3.a Nusselt numbers,  $Nu_{ii}$  at  $n = 0.5, 1.0$  and  $1.5$  (3rd kind)

Fig.3.b Nusselt numbers,  $Nu_{ii}$  at  $n = 0.5, 1.0$  and  $1.5$  (4th kind)

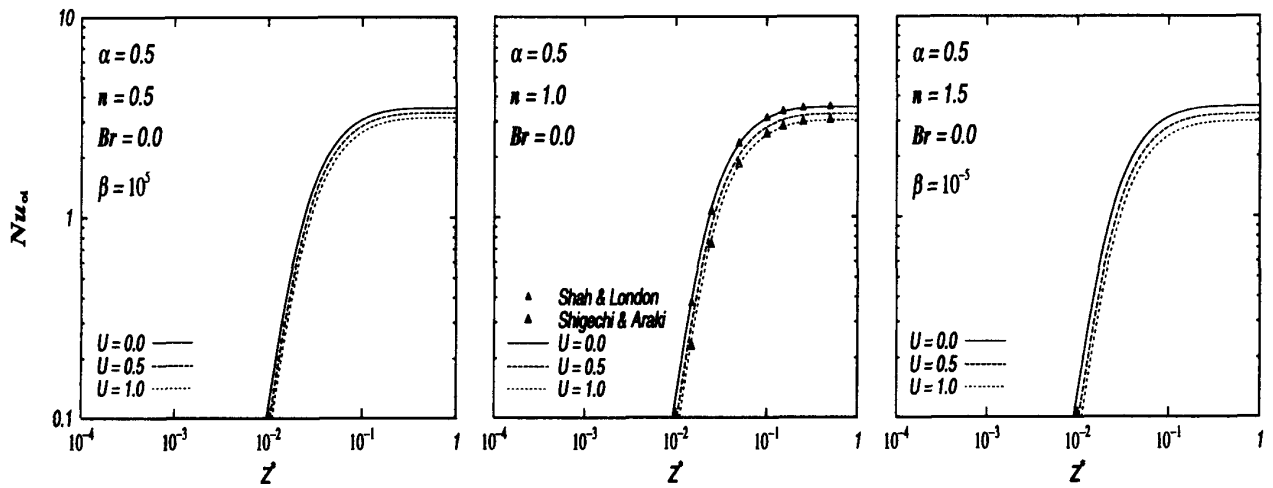

Fig.3.c Nusselt numbers,  $Nu_{oi}$  at  $n = 0.5, 1.0$  and  $1.5$  (4th kind)

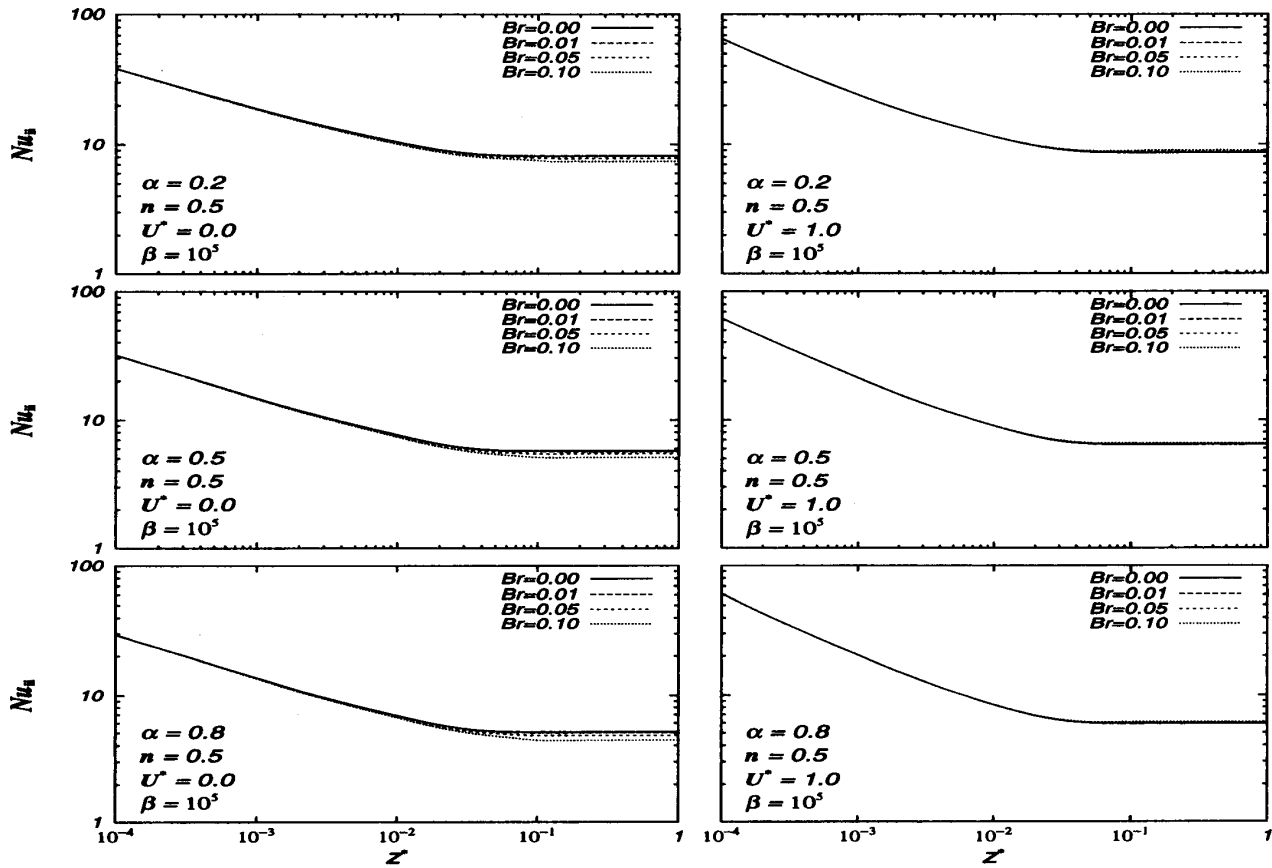

Fig.4.a Nusselt numbers,  $Nu_{ii}$ , for  $n = 0.5$ ,  $U^* = 0.0$  and  $1.0$  (3rd kind)

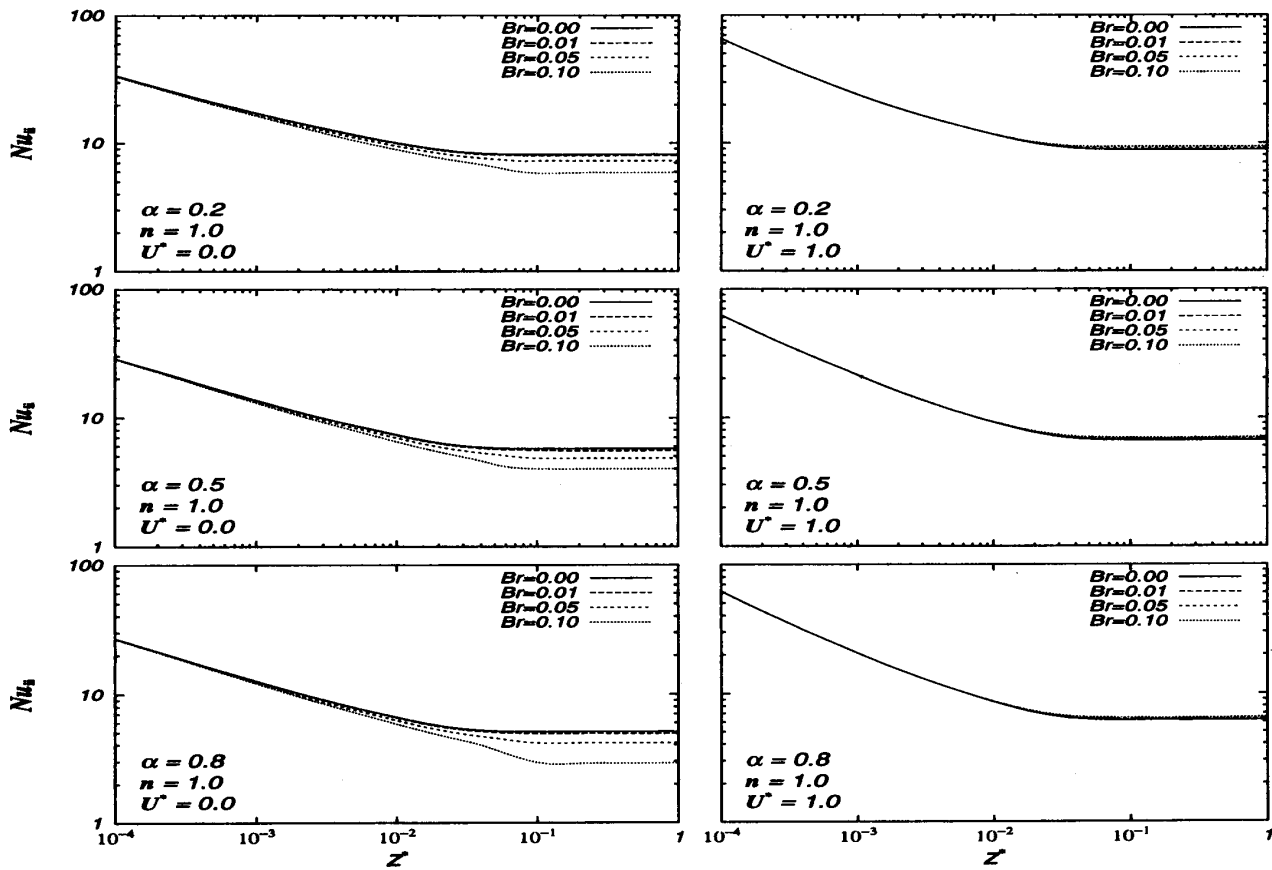

Fig.4.b Nusselt numbers,  $Nu_{ii}$ , for  $n = 1.0$ ,  $U^* = 0.0$  and  $1.0$  (3rd kind)

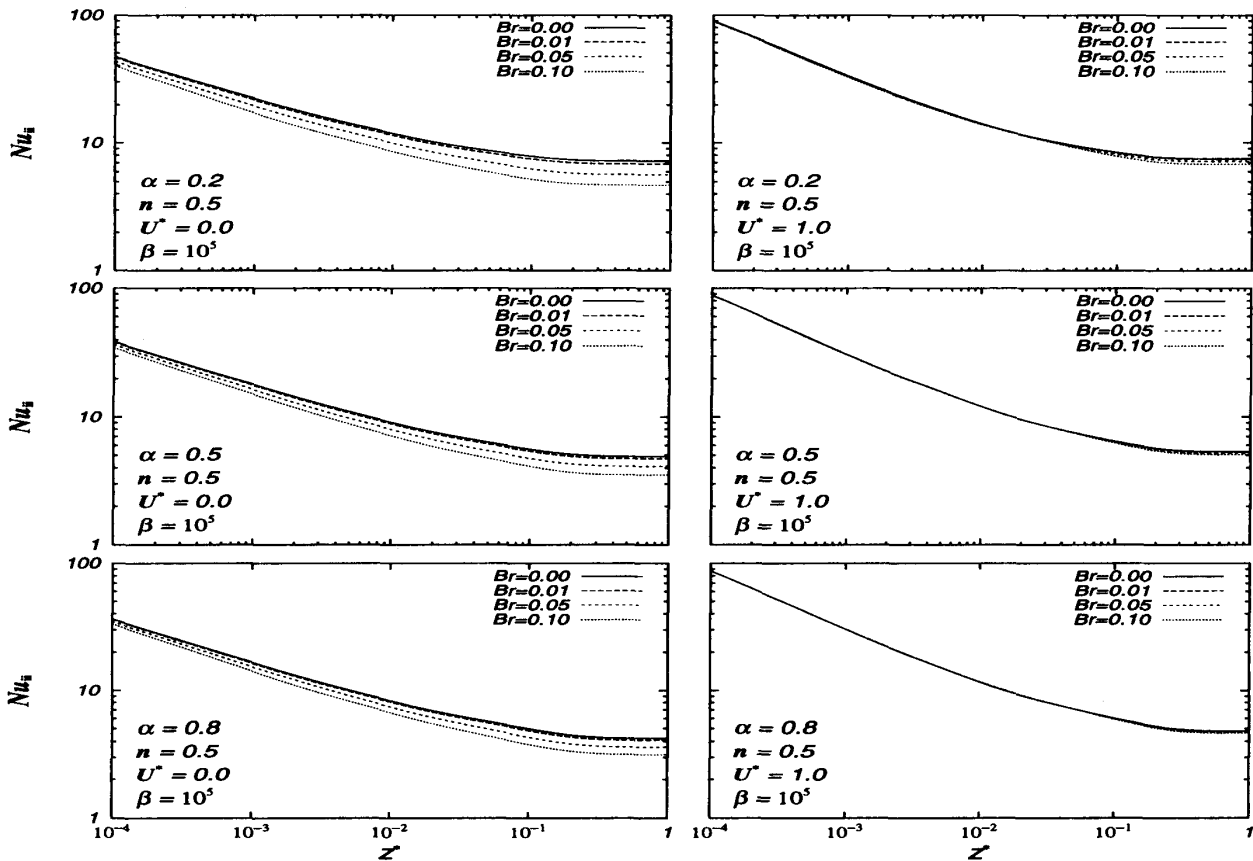

Fig.5.a Nusselt numbers,  $Nu_{ii}$ , for  $n = 0.5$ ,  $U^* = 0.0$  and  $1.0$  (4th kind)

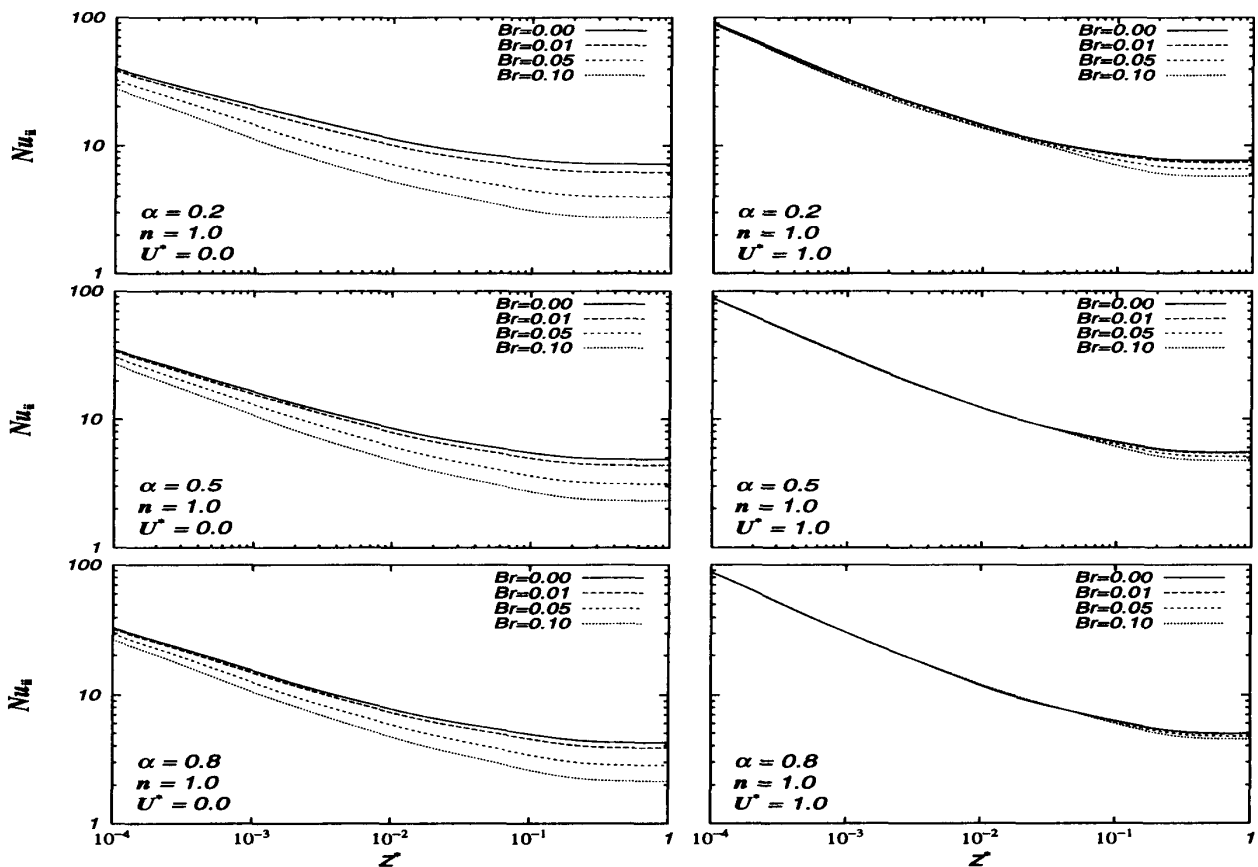

Fig.5.b Nusselt numbers,  $Nu_{ii}$ , for  $n = 1.0$ ,  $U^* = 0.0$  and  $1.0$  (4th kind)



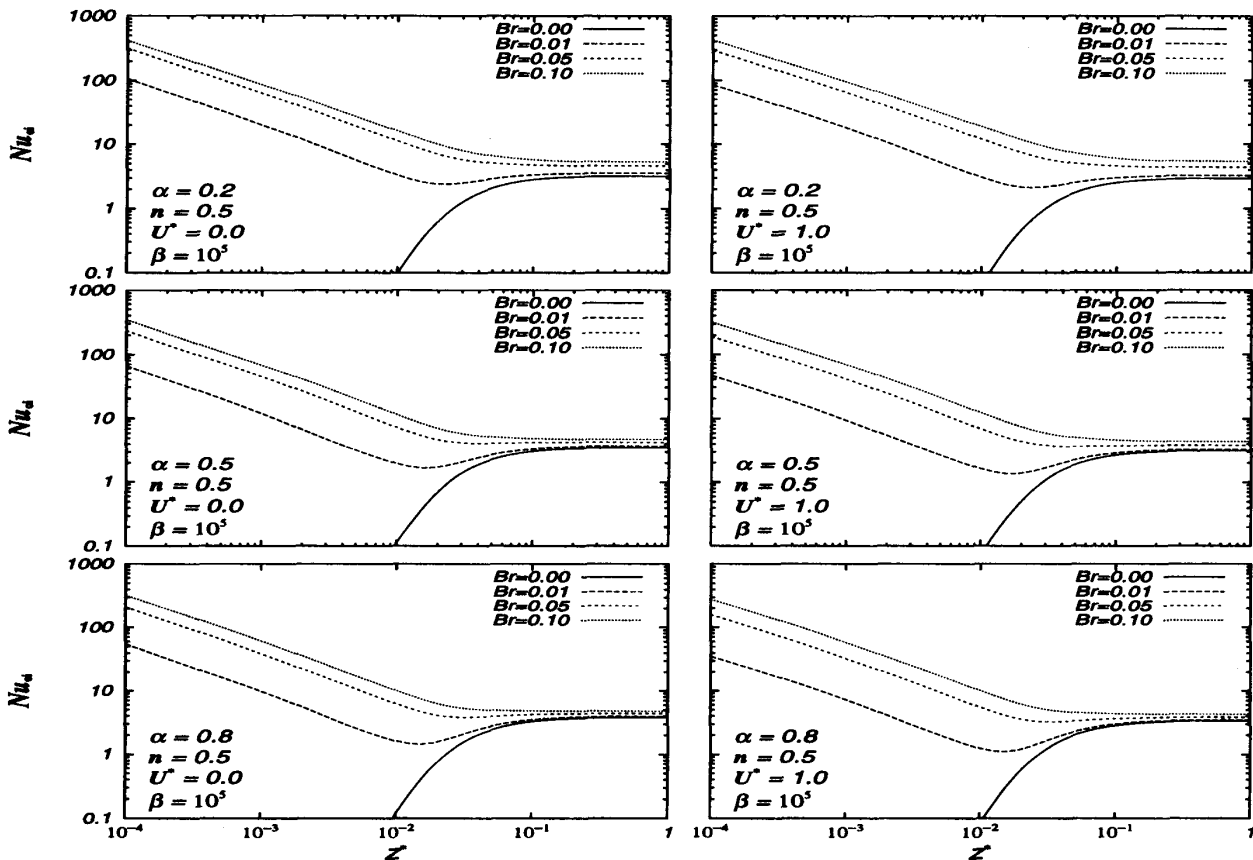

Fig.6.a Nusselt numbers,  $Nu_{oi}$ , for  $n = 0.5$ ,  $U^* = 0.0$  and 1.0 (4th kind)

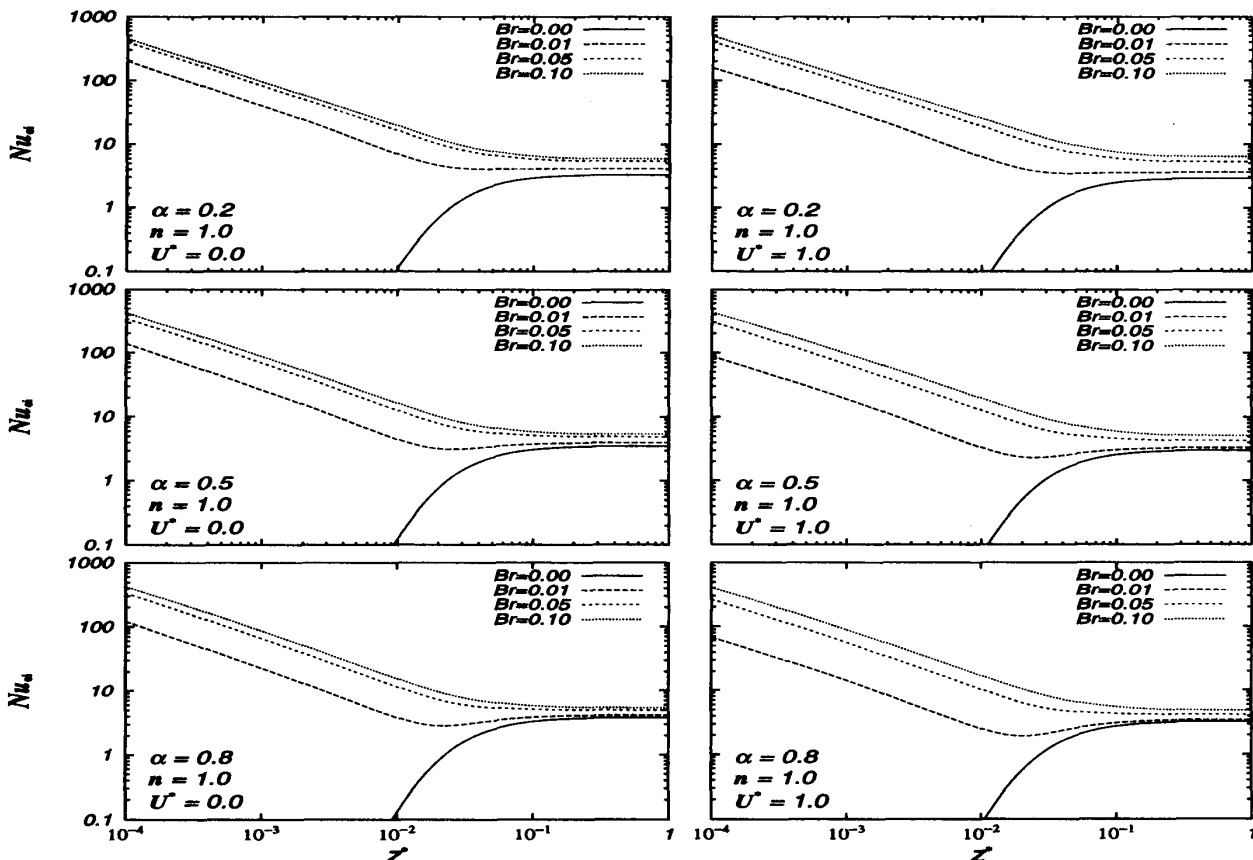

Fig.6.b Nusselt numbers,  $Nu_{oi}$ , for  $n = 1.0$ ,  $U^* = 0.0$  and 1.0 (4th kind)